

FROM THE DESK OF GARY BOSHART PRESIDENT

Summer has come and gone quickly and we are now moving into the fall season – vacations have been enjoyed, students are returning to school and families are getting back to their regular routines.

Business has been steady this summer and we anticipate that sales will continue to be strong as we head into the fall.

The Easy Grip Push Fit Fittings were introduced in our last Boshart Bulletin and have been well received. We are pleased to have added the line to our extensive product list.

We have also opened another warehouse in Milwaukee, Wisconsin which is run by our reps - JFL Marketing.

Boshart Industries will be hosting the U.S. Sales Meetings Sept. 26 – 29 at the Waterloo Motor Inn, Waterloo and the Head Office in Milverton. Our Team has been busy making the final arrangements for this event and we are looking forward to meeting with our Reps.

GETTING TO KNOW.....

Liz Gascho, Credit Manager

I started with Boshart Industries in August 1996 covering for a maternity leave. I am still here all these years later. I am the voice that you hear when you phone in and are placed on hold.



I live in Milverton with my husband of 26 years, Brian and our 3 children, Nathan, Cory and Erica. From September to March you can find us at our local arena (and many other arenas) watching and/or participating in hockey games. At one point in time, we all played the game (4 goalies and 1 defenseman). I have also been known to coach either baseball or hockey (depending on the season). From May to September we spend our weekends and holidays at our trailer. My hobbies include reading, knitting and baking.

In my spare time, I volunteer with various committees at my church and I sing in the choir.

UPDATE ON EASY-GRIP PUSH FIT FITTINGS

Please note that the updated information now shows the various approvals for the Easy-Grip Push Fit Fittings.

Contact your Inside Sales Rep for a complete Part No. listing or check the home page of the Boshart website.



Boshart EASY-GRIP Push Fit Fittings and Valves are available in sizes from 1/2" to 1" designed for connecting fittings and valves to Copper, CPVC and PEX Pipe and are ideal for use on plumbing, water heaters and hydronic heating systems. Due to their unique design utilizing high quality EPDM O-ring and #304 Stainless Steel gripper ring no soldering, crimping, or solvent welding is necessary.

SIMPLY PUSH, CONNECT AND GO!

APPLICATIONS:

- Potable Water and Hydronic heating systems - approved for use for both underground and behind walls with/without access panels.
- New residential and commercial construction - a fast easy way to plumb jobs.
- Excellent for wet, hazardous and dry repairs of existing plumbing. Excellent for wet repairs where a system is hard to drain making soldering difficult with no drying time required, a safe method to repair piping in hard to access situations where open flame could be a fire hazard for soldering.

FEATURES:

- Connects Copper, CPVC and PEX pipe in any combination. For tube sizes 1/2" (0.625" O.D.), 3/4" (0.875" O.D.), 1" (1.125" O.D.)
- Full fluid flow (without stiffener inserts)
- Fast installation, fittings can be rotated after assembly for easier installation in tight spaces - No tools required.
- No soldering, flux, clamps, unions or glue.
- High quality materials including Stainless Steel Gripper ring and EPDM O-ring.
- Integral tube liner for PEX installations.
- Easy to disconnect if needed. Disconnection of a joint can only be accomplished by using a special disconnect tool (plastic disassembly clip) to release the tube.

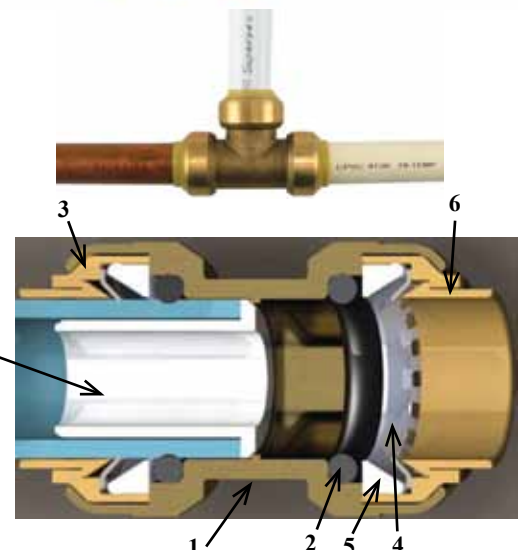

CONSTRUCTION/RATINGS

- Max Pressure 200 psi (1378 kPa)
- Max Temp 200°F (93°C) - Water
- Threads : ASME / ANSI B1.20.1
- Material: ASTM B124, ASTM B-283

Tested By:



IAPMO Certification

Products comply with the applicable sections of the latest edition of the Uniform Plumbing Code® and the International Plumbing Code®. Models listed to the National Plumbing Code of Canada and Relevant Canadian Standard(s) shall bear the cUPC mark of conformity.

Ball Valves – IAPMO File No. 5598

- Manufactured in compliance with IGC 157-2010.

Push Fit Fittings – File No. 5550

- Push fit fittings can be utilized in underground applications and as manufactured joints without access panels. To be installed in accordance with the manufacturer's instructions and the latest edition of the Uniform Plumbing Code.
- Manufactured in compliance with ASSE 1061-2006.

IAPMO Drinking Water System Components

– Health Effects File No. N-5213

Products comply with the applicable sections of the International Plumbing Code®. Manufactured in compliance with NSF/ANSI 61-2008.

Part	Material	
1	Body	C36500 Brass (Cu=60%, Pb=0.6%,
2	O-Ring	EPDM (Ethylene Propylene Diene
3	Locking Ring	POM (Polyoxymethylene)
4	Gripper Ring	S.S. 304 (Stainless Steel #304)
5	Seat Ring	POM (Polyoxymethylene)
6	Push Ring	POM (Polyoxymethylene)
7	Stiffener	PSU (Polysulfone)

In compliance with:



NEW PRODUCT NOW AVAILABLE

PREMIUM WATERTIGHT CAST IRON CAP WITH SCREENED AIR VENT

Part No. WTCL-C08

Application: For capping 8" domestic or industrial wells to ensure vermin proof/watertight sealing to the well casing. The 8" cap fits both steel or PVC well casings with an 8-5/8" outside diameter.

Features:

- Absolutely the EASIEST & FASTEST heavy duty well cap to install, easy to access well for maintenance.
- Casing stop is built into the lower ring assembly, therefore the top cover does not have to be attached to the lower ring to find the proper location on the casing, and this greatly reduces the weight / awkwardness when affixing the lower compression ring assembly to the well casing.
- The well cap has a deep socket to ensure that the gaskets seals down from the top edge of the well casing. This compensates for well casings that have not been cut off straight to ensure the cap will seal 100% on every installation.
- The top cover of the cap can easily be removed without disturbing the seal to the well casing, or interfering with the wiring or conduit.
- Top cover is sealed to the lower assembly by compressing a soft, thick durable SBR gasket that will stand the test of time and last through repeated removal and replacement of the top cover for servicing the well. It is held in perfect position by the middle ring casting making installation a breeze.
- Large 2" FPT conduit connection.
- Caps are supplied with a ground bolt and two ring terminal connectors. The middle ring has three S.S. grounding set screws to bond the well cap to the well casing (steel).
- Locking feature provides a secure / tamper proof design. Simply insert a padlock thru the S.S. locking pin.
- Large 2" mushroom vent cap with SS screen is provided as standard equipment to ensure the cap is Vermin Proof.
- Replacement of the vent with a standard 2" MPT thread plug quickly converts this vented well cap into a truly watertight cap where and when required.
- Caps are supplied with a grounding screw and two ring terminals as standard equipment.
- Personalization is available by means of an engraved aluminum plate.
- Individually boxed, with a gross shipping weight of 32.04 lbs, the well cap has a net weight of 30.73 lbs.



Construction:

- Three Piece Heavy Duty design.
- High quality grey cast iron castings
- All hardware is Stainless Steel for maximum corrosion resistance (No Plated Fasteners).
- Thick soft SBR rubber gasket with dual taper to ensure a positive watertight compression seal to the well casing.
- Top cover is sealed to the lower assembly by a thick durable SBR gasket, which is formed to fit the casting to maintain proper position and alignment.
- Durable blue powder coat paint, which is baked to ensure superior quality finish.



BOSHART BIRTHDAYS

Happy Birthday to the following Boshart employees:

September

Karen Sage
Arnie Gaunt
Lena Streicher

October

Paul Baier
Susan Kuepfer
Rod Doucet
Calvin Kuepfer
Liz Gascho
Gudrun Hobbs
Bruce Haselgrove
Linda Jones
Krista Boshart
Curtis Priestap

BOSHART BULLETIN

This publication is to provide our Sales Representatives and key customers with up-to-date information about Boshart Industries Inc.

This is a bi-monthly publication. If you have something you would like to contribute please call 519-595-4444. Sherrin Clemmer ext.49 sherrin.clemmer@boshart.com

Boshart Industries Inc.
P.O. Box 310
25 Whaley Ave.
Milverton, ON, Canada
NOK IMO
Telephone - 1-800-561-3164
Fax - 1-519-595-4380
Web: www.boshart.com

WELCOME TO NEW REPS

Boshart Industries is pleased to welcome our new reps:

-JFL Marketing, who are located in Milwaukee, Wisconsin. JFL Marketing's territory covers Northern Illinois, Wisconsin & Upper Peninsula of Michigan (Plumbing/Industrial); North Dakota, South Dakota, Minnesota (Water Well/Plumbing/Industrial/Irrigation). JFL will also be a Stocking Location for our products.

-Cascadia Sales Group, Inc. who are located in Portland, Oregon. The Cascadia Team will cover the territory of Oregon, Washington and Montana for the Water Well, Plumbing, Irrigation and Industrial markets.

BLOW-OUT SPECIALS

Be sure to take advantage of our various Blow-Out Specials of surplus product, which are forwarded to you by your Sales Rep.

Also, please note that the Boshart website has a partial list of Surplus products that are available. Go to www.boshart.com, click on Products, then on Surplus Products. You can also contact your Inside Sales Rep for a complete list, pricing, and additional information.

BOSHART STAFF SUMMER EVENTS



Chefs: Pete Exel, Jeff White

The Boshart Recreation Committee - Jeff White, Heather McEwen, Erica Baier, Peter Exel, Susan Bedard - work very hard in planning various events for the staff. During the summer months, they put on barbecues at noon, the Friday before the holiday weekends.



Left to Right: Gary Boshart, Jeff White, Susan Bedard, Heather McEwen, Erica Baier

At the barbecues, there are also a variety of prizes for the lucky winners of the draws. The prizes are purchased using the monies raised from the bi-weekly 50/50 draws.

The staff and their families also enjoyed the annual Boshart Picnic which was held this year on Sat., Aug. 14th.

Thank you to Gary for supporting and sponsoring these events.

UPCOMING TRADE SHOWS

Show	Location	Date
CIPHEX WEST	BMO Center, Stampede Park, Calgary, AB	Nov 3-4
International Pool & Spa	Mandalay Bay Convention Center Las Vegas, NV	Nov 3-5
International Irrigation	Phoenix Convention Center Phoenix, AZ	Dec 5-7
NGWA	Las Vegas Convention Center Las Vegas, NV	Dec 8-9